





## Instructions

Decorate the four sides of the house in colours/papers of your choice and slot together the four sides of the house.

Take 6 of the 12 concertina chipboard pieces (50mm x 60mm). These need to be glued to a piece of thick paper (350mm x 60mm). Lay out the 6 pieces so there is a 10mm gap between them. Then glue another piece of thick paper to the other side. Fold the pieces concertina style. Repeat with the other 6 chipboard pieces.



Take the middle section (90mm x 100mm) and decorate as required.

Glue one end of the concertina piece on to the middle section as centrally as possible.

It should look as shown:

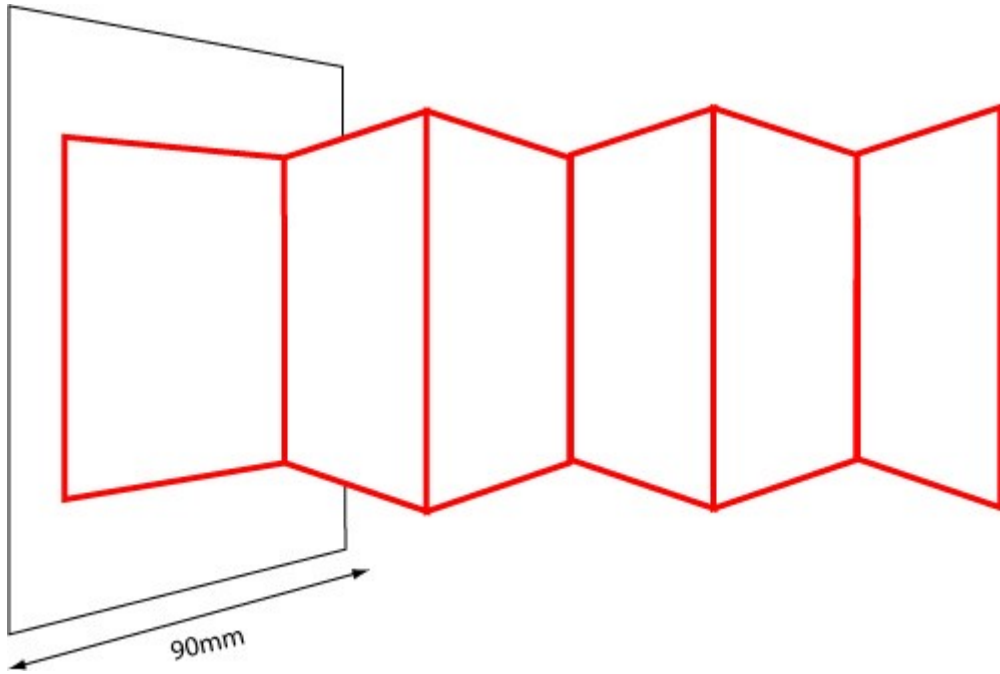

Repeat with the other concertina piece.



Measure the house base and draw a line as shown in red below on one side only.

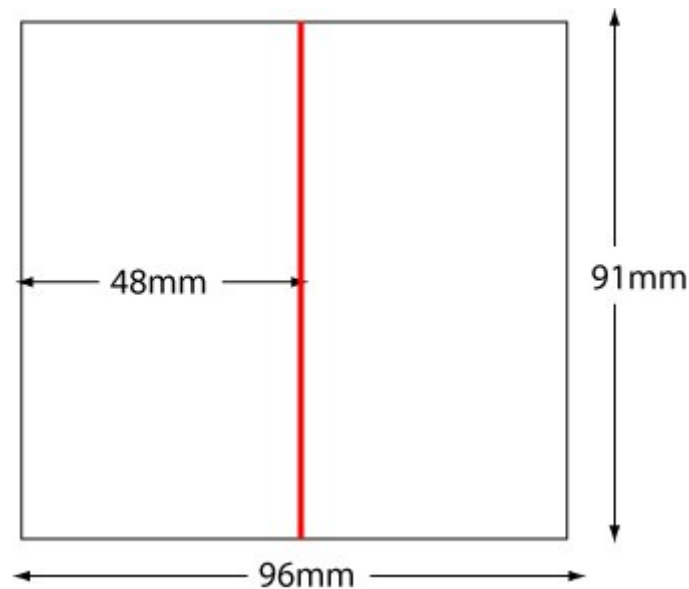

Apply glue around the edge of the base, place the base flat on your work surface with the drawn line showing upwards. Place the house over the top and gently manoeuvre the house body so the base slips inside. Hold firm until the glue is dry.

11/. The middle section needs to be glued inside the house and the base of the middle section will align with the drawn line on the base done earlier. As the middle section needs to sit as upright as possible it's a good idea to just measure the halfway point on the inside of the two pitched sides of the house. Then when you insert the middle section you will have a guide for the top as well as the bottom.

Run glue along the bottom edge and on the two 100mm edges. Hold the concertina sections in and slide the middle section down into the middle of the house.

Line up the bottom with the drawn line on the base and the tops with the measured halfway point on the pitched sides.

At this point the concertina pieces should fold in and out of the apertures on the sides of the house.



12/. Take the two outer sections (80mm x 90mm), cover one side with patterned paper and paint the other side. Paint with the acrylic paint dabber Sandal and again spray with a mini mister with some Perfect Pearls, Perfect Gold and water. Make two holes in the one of the side panels and thread through the string with the wooden bead and secure on the back (the holes I made are approx. 15mm down from the top of the side panel).



13/. Join two A & B magnets together. Attach one side to the bottom of the outer panel in the middle. Do the same at the top. The magnets I used could have ideally been a little smaller so be careful when placing them at the top. You need to make sure that they won't interfere with the concertina piece moving in and out nor do you want the roof piece stopping concertina movement. Repeat on the other outer panel. Don't attach the outer panels to the concertina piece just yet.

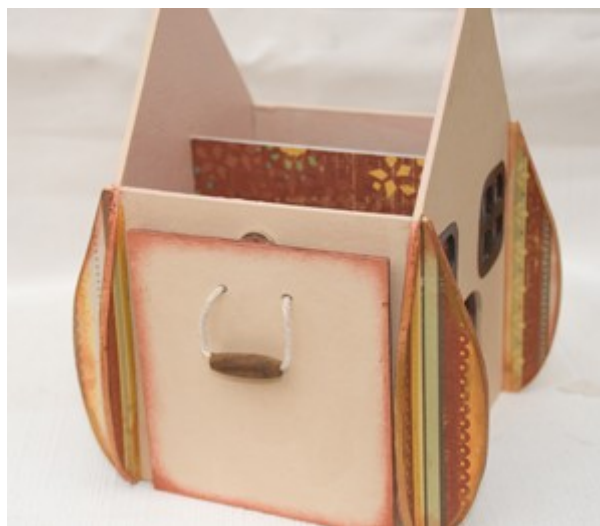

14/. Now decorate the embellishments for the outside of the house. I have painted the two cloud trees with willow and espresso paint dabbers and added some shading to the leaf area and trunk with some green petina perfect pearls.



I painted the flower rows with perfect pearls...forever red, perfect gold and green petina. I have left the very bottom of two of the flower rows as I will be cutting them off.



Take the swing base chipboard piece and ink all sides. Cut a couple of pieces of thin string and tie a loop at one end. Place them over each end of the swing base and glue to the bottom. Make a couple of holes in the small chipboard tree and pass the string through to make the swing. Glue the string securely on the back.



To make the door: I took the two pieces of chipboard 45mm x 55mm and cut an arch shape at the top across the 45mm dimension. Then cut one of the pieces into 4 strips. I inked the front with the dewdrop ink...red... , I then inked the edges in black but softened with a brown inkpad. Glue the four pieces onto the matching piece.

I made the sign by cutting a small shape from a spare piece of chipboard, painted it white and inked and softened the edges with a brown ink pad. I finished off by hand writing Our Home on the sign.

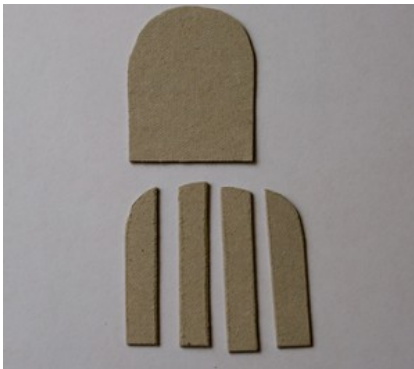

Glue the small tree to one of the side panels, glue the door to the front, glue one of the flower rows to the side with the bead, add the large tree to the back and randomly place the flowers cutting some of them from the chippie base to separate them.





15/. Now glue the two outer panels to the concertina sections inside being careful to keep them as central as possible so the concertina sections still move in and out easily.



16/. I then decided I wanted to stamp a flourish on the front of the house using one of the Inkadinkado stamps: 60-30049 Artistic Flourish



17/. For the roof panels I have used the stampers anonymous stamp Creative Textures CMS004. Whilst the ink is still wet quickly ink the top around the edge and then sprinkle ultra thick embossing powder over the top. Melt with a heat gun. I have also embossed the part of the underside of the roof that is visible once glued on.



Glue the panels to the top of the house with a good strong glue.

18/. Construct the chimney panels and paint in red pepper. I then added a coat of perfect gold perfect pearls and dabbed dry to make an interesting finish. Glue the chimney to the roof of the house.....any you're done.

© Copyright Tando Creative Limited April 2010